



GHKE-62S-MCI

Fork Properties

900 Kgs. Load Capacity Forged Kingpinless Castors

- Single piece forged alloy steel top plate & fork base
- Precision CNC machined raceways
- Induction hardened raceways ensure swivel head longevity
- Totally sealed swivel head with grease nipple
- 6mm thick fabricated construction of forks robotically welded inside & outside to 65mm fork spacing
- 12mm Wheel Axle
- Finish: Zinc plate; ROHS compliant or Black polymer color coated
- Options : 4 way directional lock, Total lock, Wheel face break

Wheel Properties

Muvtons special grey cast iron wheels solid core construction, tread face fully machined and crown treaded for extremely easy maneuverability. These wheels offer high abrasion and oil resistance can be used upto 600°C with appropriate wheel bearings. Wheel bearing options: Sealed precision ball bearings, tapered roller bearings or roller bearings. Temperature range : -100°C to +600°C.

Technical Data

Castor Type	Swivel Castor without Brake
Wheel Material	Cast Iron
Wheel Dia(mm)	150
Tread Width(mm)	50
Load Capacity(kg)	800
Wheel Bearing	Ball Bearing
Overall Height(mm)	195
Swivel Radius(mm)	115
Top Plate(mm)	138 x 110
Bolt Hole Dia(mm)	105 x 75-80
Non Marking	-
Heat Resistant	yes
Noise Reduction	-

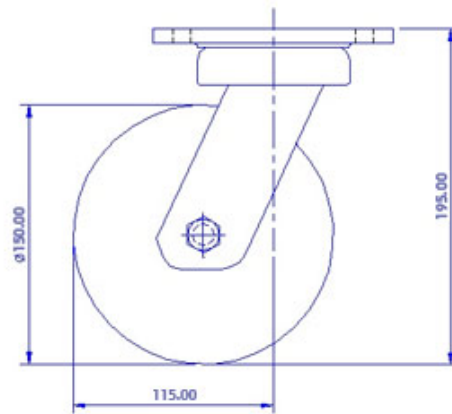

FRONT VIEW

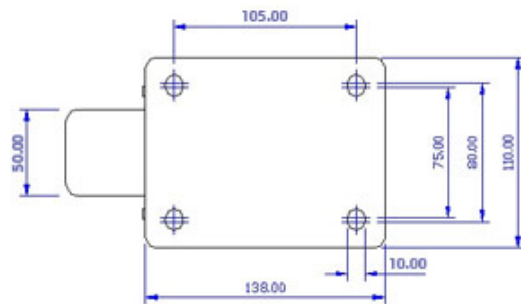

TOP VIEW