



GHKE-62S-ME

Fork Properties

900 Kgs. Load Capacity Forged Kingpinless Castors

- ▢ Single piece forged alloy steel top plate & fork base
- ▢ Precision CNC machined raceways
- ▢ Induction hardened raceways ensure swivel head longevity
- ▢ Totally sealed swivel head with grease nipple
- ▢ 6mm thick fabricated construction of forks robotically welded inside & outside to 65mm fork spacing
- ▢ 12mm Wheel Axle
- ▢ Finish: Zinc plate; ROHS compliant or Black polymer color coated
- ▢ Options : 4 way directional lock, Total lock, Wheel face break

Muvtons Ergonomic wheels for effortless rolling, very low push pull efforts required to move heavy loads. Generous amount of premium polyurethane 93° ±3° Shore A firmly bonded, mechanically & chemically to precision machined cores. Proven for excellent chemically, to precision machined cores. Proven for excellent performance in most demanding applications for manual and power performance in most demanding applications for manual and power towing. They are non-marking and floor protective. Tested & Guaranteed against bond failures. Softer 83° ±3° Shore A durometer for greater tractive resistance and harder 73° ±3° Shore D polyurethane treads for extremely low rolling resistance are also offered. Wheel bearing options: Sealed precision ball bearings, tapered roller bearings or roller bearings. Temperature range : -20°C to +85°C Tread Options : Anti-static; conductive wheels are available.

Technical Data

Castor Type	Swivel Castor without Brake
Wheel Material	Polyurethane
Wheel Hardness	93° ± 3° Shore A
Wheel Center	Cast Iron
Wheel Dia(mm)	150
Tread Width(mm)	50
Load Capacity(kg)	575
Wheel Bearing	Ball Bearing
Overall Height(mm)	195
Swivel Radius(mm)	115
Top Plate(mm)	138 x 110
Bolt Hole Dia(mm)	105 x 75-80
Castor Pdf File Name	-
AutoCAD File Name	yes
Non Marking	yes
Heat Resistant	-

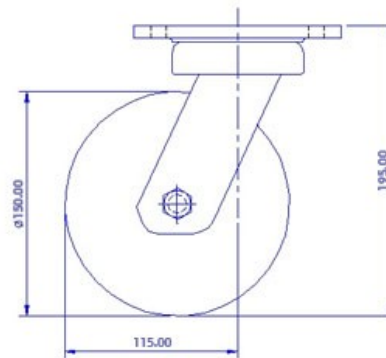

FRONT VIEW

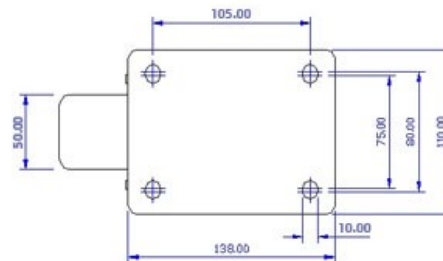

TOP VIEW