



## SAB-52S-SZS

### Fork Properties

#### 1500kgs load capacity forged precision bearing castors.

- Single piece forged alloy steel top plate with an integrally forged kingpin & forged fork base.
- Combination of Precision thrust bearing and tapered roller bearing in the swivel head
- Totally sealed swivel head with grease nipple
- Slotted nut and cotter pin arrangement allow adjustment of swivel head play during usage
- 6 mm thick cylindrical formed legs robotically welded inside & outside to 65 mm fork spacing
- 12 mm wheel axle
- Finish : Zinc Plated ; ROHS Compliant or Black polymer colour coted
- Options : 4 way directional lock, total lock, wheel face brake

### Wheel Properties

Muvtons Premium Soft Durometer Polyurethane treaded wheels 83° ±3° Shore A, firmly bonded to precision machined cast iron cores. These wheels have been designed in response to noise problems and allow loads to be cushioned. The use of 'lively' polyurethane materials allows these wheels to 'flex & roll' over debris and obstacles without picking up objects. They are non-marking and floor protective. Tested & Guaranteed against bond failures. Wheel Bearing Options : Sealed precision ball bearings, tapered roller bearings or roller bearings. Temperature range: -20° C to +85° C. Tread Options : Anti-static ; conductive wheels are.

### Technical Data

Castor Type	Swivel Castor without Brake
Wheel Material	Polyurethane
Wheel Hardness	83° ± 3° Shore A
Wheel Center	Cast Iron
Wheel Dia(mm)	125
Tread Width(mm)	50
Load Capacity(kg)	350
Wheel Bearing	Ball Bearing
Overall Height(mm)	175
Swivel Radius(mm)	120
Top Plate(mm)	138 x 110
Bolt Hole Centers	105 x 75-80
Non Marking	Yes
Heat Resistant	Yes
Noise Reduction	Yes

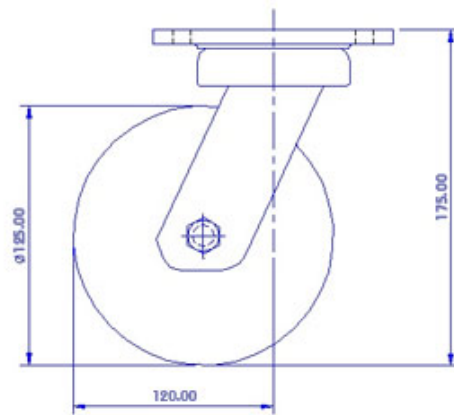

FRONT VIEW

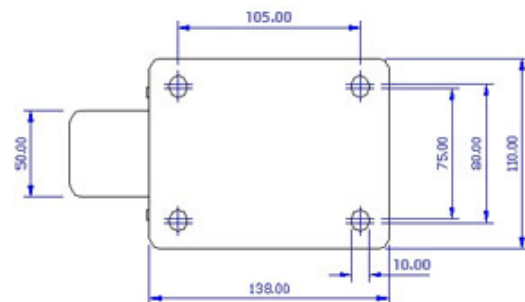

TOP VIEW